

TREADBRITE TEXTURE NOT  
SHOWN IN TOP VIEW

REFERENCE SCALE IN INCHES

COMP.	HEIGHT	WIDTH	USABLE DEPTH		DIVIDE	FT*
			UPPER	LOWER		
DFW	36.62	75.88	-	28	-	45.04
PFW	36.62	75.88	-	28	-	45.04

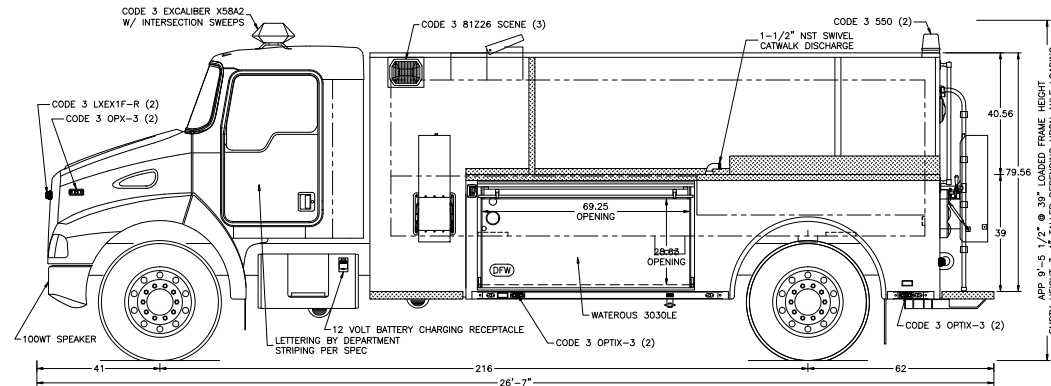
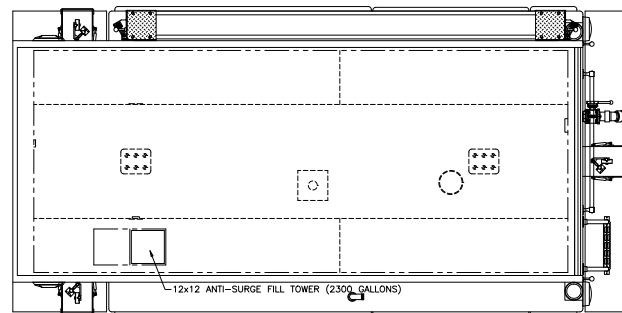

**NOTE:**

DIMENSIONS SHOWN ARE APPROXIMATE AND ARE SUBJECT TO MINOR CHANGE AS MAY BE FOUND NECESSARY DURING CONSTRUCTION. MINOR DETAILS MAY NOT BE SHOWN. IF DISCREPANCIES EXIST BETWEEN THIS DRAWING AND THE WRITTEN SPECIFICATIONS PROVIDED BY TOYNE, THE WRITTEN SPECIFICATIONS SHALL PREVAIL.

CHASSIS: KENWORTH T370  
WB-CA: 216"-148"-43"  
BODY: ALUMINUM  
PUMP: WATEROUS 3030LE  
TANK: 2300 UPF POLY  
GENSET: N/A  
FOAM: N/A

**TOYNE FIRE APPARATUS**  
BREDA, IOWA 51436  
**9449 DEMO**  
COMMERCIAL TANKER

SCALE: 1/64 CAD BY: SCHMCHR DISC:  
DATE: 18 MAY 2009 9449-A